



Email: sales@vikingltd.aero

Phone: +44 (0) 1706 875 139

<https://www.viking-ltd.com>

MANUFACTURERS OF CARGO AND AIRPORT HANDLING EQUIPMENT

SERIES 8 CONTAINER DOLLIES: CD428 & CD728



The Viking Airport Equipment container dolly range are designed and manufactured by our team in house to meet current IATA, BS and European standards. These one-piece welded chassis dollies offer a light but very robust structure made from high grade tensile steel with outer walls which are fabricated and folded to give them the ability to withstand reasonable collision impacts.

All container dolly variants have a top deck height of 508mm (20") and are fitted with parking bar brake to wheels, the brakes are activated upon lifting the tow bar. The chassis is fully galvanised and comes with various lift up stops to retain specific containers. Simple handle operated stops located on the sides of the dollies allow them to easily retain containers.

Safety features which meet with the latest IATA to include

- **Anti Step through barrier**
- **Pedal operated Lock down & quick release perimeter ride over wedge stops**
- **Secondary perimeter blade stop which works in conjunction with locking the ULD in position**
- **Ability to offload ULD's from one side of the trailer only, thus removing the need for personnel to step across or between trailers**

Overall lightweight construction allows one person to easily manoeuvre the container dolly. A high specification design ensures long service on the airport apron, and our full CD range operate with turn table steer as standard.

All of our container dollies are hot dip galvanised to BS EN ISO 1461, and day-glow paint to all corners and hazard stripes to side and rear walls provide high visibility in all conditions.

All of this range is available with an anti step over barrier as an optional extra.

Technical Specification

	CD428	CD728
Chassis Size (mm)	2490 x 1778	4024 x 1778
Loading	Side	
S.W.L. (Kgs)	2500	3000
Torsion Bar (Kg)	2 x 1500	2 x 1800
Shock Absorption Axles	Yes	
Wheels	4 off 400 x 75 x 8 Solid rubber cushion tyres	
Front Axle Mount	Through 500mm ball bearing	Through 850mm ball bearing
Loading Height	508mm	
Park Brake	When tow bar Apex is raised	
Tow Bar	50mm Tow eye in pivoting delta shape	
Top Deck Castors	102mm with lead on side rollers	
Rear Tow Bar	Viking Standard Spring Loaded	
Stops	Foot pedal operated side stops. Stop bar operated side stops. Fixed headboards front and rear.	

Our range of container dollies provide you with options for moving various ULD's around the airport apron.

Table shows potential to handle if not exceeding the S.W.L. of trailer.

	CD428	CD728
LD1		✓
LD2		
LD3	✓	✓x2
LD4		
LD6		✓
LD8		
LD11		✓
AKH	✓	✓

CD428

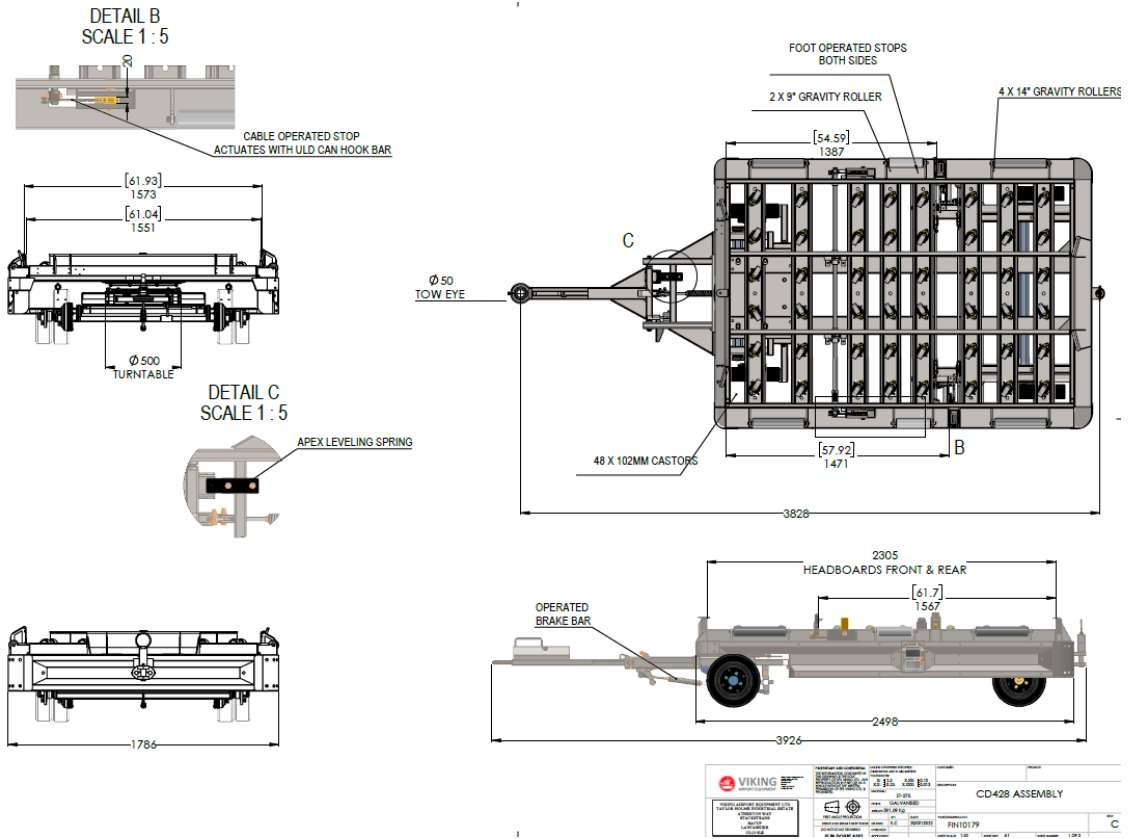

CD728

